



High performance, ruggedised 6 GHz to 18 GHz block down conversion extension for RFeye node

- **Seamless extension to standard RFeye Node frequency analysis range**
- **6 GHz to 18 GHz operating range**
- **Integrated operation with standard RFeye Node**
- **Extends full real time capability of the RFeye node to microwave bands**
- **Multiple RF ports for multi-antenna operation**
- **Support for AOA and TDOA direction finding at extended frequencies**
- **Ruggedised for operation in hostile environments**
- **Easily fitted to existing RFeye deployments**
- **Custom pre-selection filter options for customer-specific applications**

The RFeye block down converter extends the frequency range of the standard RFeye spectrum monitoring node from 6 GHz up to 18 GHz. Further frequency range extensions, from 18 GHz to 40 GHz, are available on request.

The RFeye block down converter takes a wide band of frequencies and converts them into a range that the RFeye node can then analyse using the full real time analysis capabilities of the node.

Power and control of the RFeye block down converter is supplied by the RFeye node via one of the node's expansion ports, with the RF output of the block down converter connected to one of the four antenna inputs on the controlling RFeye node.

The block down converter uses the same form factor and mounting options as the standard RFeye node, permitting standardisation of fitment and mounting options, and may be co-sited with the RFeye node, or mounted remotely.

The RFeye down converter is built to the same environmental specifications as the RFeye node and is designed for outdoor/indoor, fixed/mobile operation.

Features

- | | |
|--|---|
| <ul style="list-style-type: none"> • Rugged, lightweight, compact, low power and fully IP rated • Wide frequency range: 6 GHz - 18 GHz in one module • Multiple RF ports to support multi-antenna operation • Fast synthesiser tuning and pre selection filtering • Fixed and mobile applications | <ul style="list-style-type: none"> • System architecture optimised for seamless RFeye node frequency extension • Identical form factor to standard RFeye Node for easy integration with existing RFeye installations • Power and control from RFeye Node, or can be used in stand-alone mode if required |
|--|---|

Architecture

**Standard RFeye node sweeping
10 MHz to 6 GHz**

Up to 4 x antennas supported by standard RFeye node with the ability to add further antenna switches supporting AOA DF options

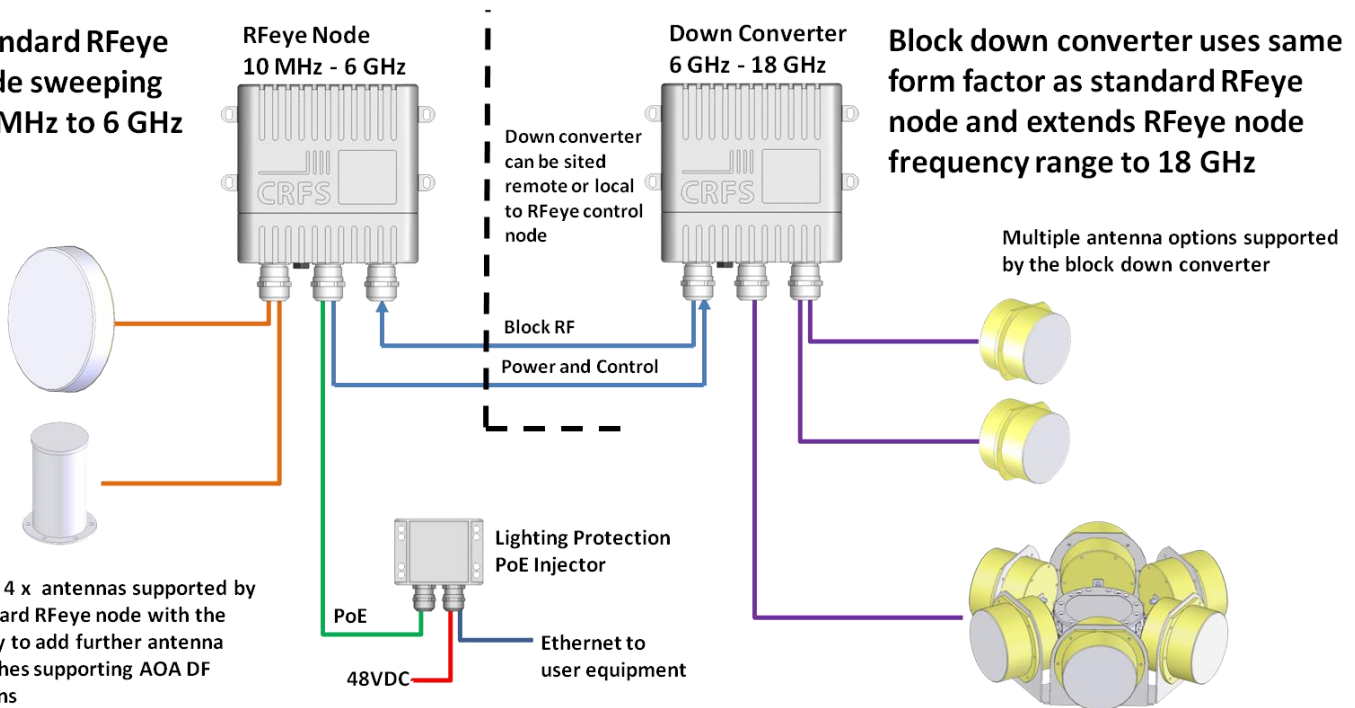

The RFeye down converter architecture allows more than one down converter device to be connected to a single RFeye node, giving the RFeye node the ability to seamlessly analyse a very wide frequency range using the same PC analysis tools and Spectrum Management System software. The down converter can be retrofitted to any existing RFeye installation.

Technical Specification

Frequency

Range	6 GHz to 18 GHz
IF Bandwidth	3 GHz
IF Centre Frequency	2.5GHz and 3.5GHz band dependant
Gain	15dB
Phase Noise	-110 dBc/Hz @100kHz typical
Preselection bands * (Standard)	6 - 9 GHz 9 - 12 GHz 12 - 15 GHz 15 - 18 GHz
*Custom bands	Option to fit custom filters to add extra out of band rejection in specific bands

Interfaces

RF input	4 switchable inputs (SMA)
DC power via RFeye node	6 VDC via control cable
DC power from external source	10 - 48 VDC
Power consumption	4 W typical
Reference clock input	10 MHz from RFeye Node

Sensitivity (equivalent noise figures at maximum sensitivity)

6 GHz - 15 GHz	9 dB typical **
15 GHz - 18 GHz	10 dB typical **
	(** with 4 way antenna selection switch option at front end)

Signal Input

Input connector	Four switchable SMA inputs
Maximum input level	+15 dBm; 15 VDC

Signal Output

Output connector	Single SMA output
Maximum output level	-20 dBm

Mechanical

Dimensions (w h d)	170 mm x 60 mm x 125 mm (6.7 in x 2.4 in x 4.9 in)
Weight	2.0 kg (4.4 lb) [with environmental protection cover]

Environmental

Operating temperature	-30 to +55°C (-22 to 131 °F)
Storage temperature	-40 to +70°C (-40 to 158 °F)

For more information